

### Słupek z tworzywa z gwintem M3 wewnętrzny i zewnętrznym

Wykonane z poliamidu GV,  
tolerancja wysokości +/-0.1mm  
kolor czarny  
klucz nasadowy **SW 6,0**  
temperatura pracy -45 - +110<sup>0</sup> C  
opakowanie 100 szt

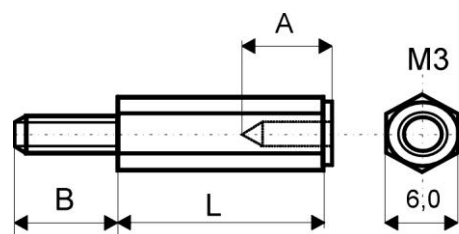

Symbol	L (mm)	B(mm)	A(mm)
AB3x 6IAK	6	8,0	3,5
AB3x 8IAK	8	8,0	4,0
AB3x 10IAK	10	8,0	5,0
AB3x 12IAK	12	8,0	6,0
AB3x 15IAK	15	8,0	10,0
AB3x 18IAK	18	8,0	10,0
AB3x 20IAK	20	8,0	10,0
AB3x 25IAK	25	8,0	10,0
AB3x 30IAK	30	8,0	10,0
AB3x 35IAK	35	8,0	10,0
AB3x 40IAK	40	8,0	10,0
AB3x 45IAK	45	8,0	10,0
AB3x 50IAK	50	8,0	10,0



### Słupek z tworzywa z gwintem M3 wewnętrzny

Symbol	L (mm)	A(mm)
AB3x 5IIK	5	5,0
AB3x 6IIK	6	6,0
AB3x 8IIK	8	8,0
AB3x 10IIK	10	10,0
AB3x 12IIK	12	12,0
AB3x 15IIK	15	15,0
AB3x 18IIK	18	8,0
AB3x 20IIK	20	10,0
AB3x 25IIK	25	10,0
AB3x 30IIK	30	10,0
AB3x 35IIK	35	10,0
AB3x 40IIK	40	10,0
AB3x 45IIK	45	10,0
AB3x 50IIK	50	10,0

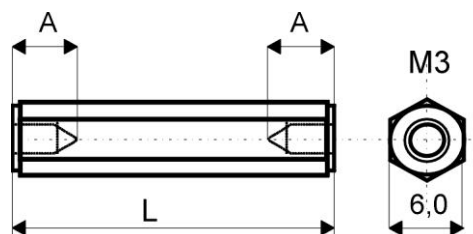

### Słupek z tworzywa z gwintem M3 wewnętrznym i zatrzaskiem

Wykonane z poliamidu GV,  
tolerancja wysokości +/-0.1mm  
kolor czarny  
klucz nasadowy **SW 6,0**  
temperatura pracy -45 - +110<sup>0</sup> C  
opakowanie 50 szt



Symbol	L (mm)	A(mm)
AB3x 6IEK	6	3,0
AB3x 7IEK	7	3,5
AB3x 8IEK	8	4,0
AB3x 9IEK	9	5,0
AB3x 10IEK	10	6,0
AB3x 11IEK	11	6,0
AB3x 12IEK	12	7,0
AB3x 13IEK	13	7,0
AB3x 14IEK	14	7,0
AB3x 15IEK	15	8,0
AB3x 16IEK	16	8,0
AB3x 17IEK	17	9,0
AB3x 18IEK	18	9,0
AB3x 20IEK	20	10,0
AB3x 25IEK	25	10,0
AB3x 30IEK	30	10,0
AB3x 35IEK	35	10,0
AB3x 40IEK	40	10,0
AB3x 45IEK	45	10,0
AB3x 50IEK	50	10,0

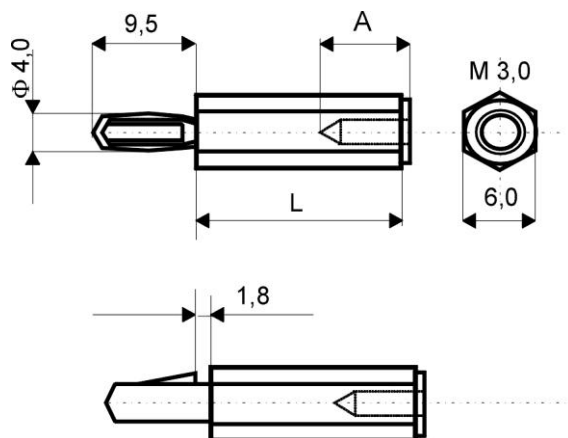

### Słupek z tworzywa z gwintem M4 wewnętrznym i zewnętrznym

Wykonane z poliamidu GV,  
tolerancja wysokości +/-0.1mm  
kolor czarny  
klucz nasadowy **SW 8,0**  
temperatura pracy -45 - +110<sup>0</sup> C  
opakowanie 100 szt



Symbol	L (mm)	B(mm)	A(mm)
AB4x 8IAK	8	8,0	6,0
AB4x 10IAK	10	8,0	7,0
AB4x 12IAK	12	8,0	9,0
AB4x 15IAK	15	8,0	10,0
AB4x 18IAK	18	8,0	10,0
AB4x 20IAK	20	8,0	10,0
AB4x 25IAK	25	8,0	10,0
AB4x 30IAK	30	8,0	10,0
AB4x 35IAK	35	8,0	10,0
AB4x 40IAK	40	8,0	10,0
AB4x 45IAK	45	8,0	10,0
AB4x 50IAK	50	8,0	10,0

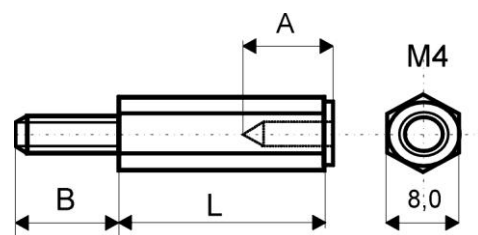

### Słupek z tworzywa z gwintem M4 wewnętrznym

Symbol	L (mm)	A(mm)
AB4x 6IIK	6	6,0
AB4x 8IIK	8	8,0
AB4x 10IIK	10	10,0
AB4x 12IIK	12	12,0
AB4x 15IIK	15	15,0
AB4x 18IIK	18	18,0
AB4x 20IIK	20	20,0
AB4x 25IIK	25	10,0
AB4x 30IIK	30	10,0
AB4x 35IIK	35	10,0
AB4x 40IIK	40	10,0
AB4x 45IIK	45	10,0
AB4x 50IIK	50	10,0

