

Śruby i nakrętki

Śruby z tworzywa

Dane techniczne

materiał	:poliamid PA 6.6
kolor	:transparentny, biały
minimalne opakowanie	:100 szt
wytrzymałość	:60-80 N/mm ²
temp. pracy	:-400 + 150 ⁰ C

symbol	gwint	wymiary (mm)		
		L	d1	k
KSZ 3 x 6	M3	6	5,5	2,0
KSZ 3 x 8	M3	8	5,5	2,0
KSZ 3 x10	M3	10	5,5	2,0
KSZ 3 x16	M3	16	5,5	2,0
KSZ 4 x 6	M4	6	7,0	2,6
KSZ 4 x 8	M4	8	7,0	2,6
KSZ 4 x10	M4	10	7,0	2,6
KSZ 4 x16	M4	16	7,0	2,6
KSZ 5 x10	M4	10	8,3	3,2
KSZ 5 x12	M5	12	8,3	3,2
KSZ 5 x16	M5	16	8,3	3,2
KSZ 5 x20	M5	6	5,5	2,0

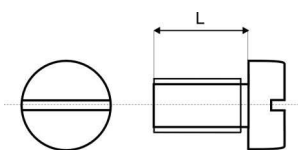

Podkładki z tworzywa

Dane techniczne

materiał	:poliamid PA6.6
temp. pracy	:-40 +110 ⁰ C
opakowanie	:100 szt

symbol:	wymiary (mm)		
	D	d	S
USK 2,0	5	2,2	0,3
USK 2,5	6,5	2,7	0,5
USK 3,0	7,0	3,3	0,5
USK 4,0	9,0	4,3	0,8

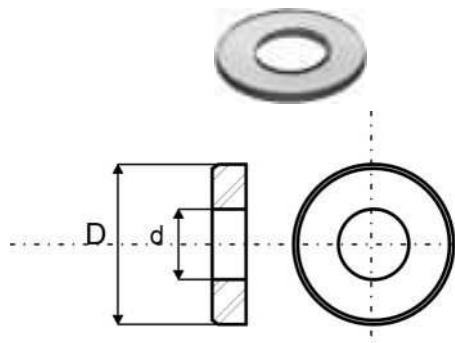

Nakrętki z tworzywa

Dane techniczne

materiał	:poliamid PA6.6
temp. pracy:	-40 +110 ⁰ C
opakowanie:	100 szt

symbol:	wymiary (mm)		
	d	S	H
KSM 2,0	2,0	4,0	1,6
KSM 2,5	2,5	5,0	2,0
KSM 3,0	3,0	5,5	2,4
KSM 4,0	4,0	7,0	3,2
KSM 5,0	5,0	8,0	4,0

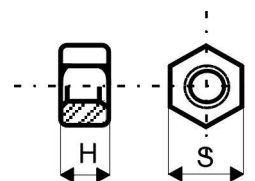

Śruby z łbem cylindrycznym

Dane techniczne

materiał :stal 4,8
pokrycie :cynkowane
opakowanie :100 szt
pod wkrętak :płaski

symbol:	gwint	Φ L (mm)	
		M	d
GEW2,0x 4Z	2	2,0	4
GEW2,0x 6Z	2	2,0	6
GEW2,0x 8Z	2	2,0	8
GEW2,0x10Z	2	2,0	10
GEW2,0x12Z	2	2,0	12
GEW2,0x16Z	2	2,0	16
GEW2,0x20Z	2	2,0	20
GEW2,5x 4Z	2,5	2,5	4
GEW2,5x 6Z	2,5	2,5	6
GEW2,5x 8Z	2,5	2,5	8
GEW2,5x10Z	2,5	2,5	10
GEW2,5x12Z	2,5	2,5	12
GEW2,5x16Z	2,5	2,5	16
GEW2,5x20Z	2,5	2,5	20
GEW2,5x25Z	2,5	2,5	25
GEW3,0x 6Z	3	3,0	6
GEW3,0x 8Z	3	3,0	8
GEW3,0x10Z	3	3,0	10
GEW3,0x12Z	3	3,0	12
GEW3,0x16Z	3	3,0	16
GEW3,0x20Z	3	3,0	20
GEW3,0x25Z	3	3,0	25
GEW3,0x30Z	3	3,0	30
GEW3,0x35Z	3	3,0	35
GEW3,0x40Z	3	3,0	40
GEW4,0x 6Z	4	4,0	6
GEW4,0x 8Z	4	4,0	8
GEW4,0x10Z	4	4,0	10
GEW4,0x12Z	4	4,0	12
GEW4,0x16Z	4	4,0	16
GEW4,0x20Z	4	4,0	20
GEW5,0x 8Z	5	5,0	8
GEW5,0x10Z	5	5,0	10
GEW5,0x12Z	5	5,0	12
GEW5,0x16Z	5	5,0	16
GEW5,0x20Z	5	5,0	20

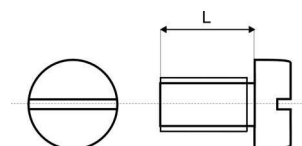

Śruby z łbem owalnym pod wkrętak krzyżakowy

Dane techniczne

materiał :stal 4,8
pokrycie :cynkowane
opakowanie :100 szt
pod wkrętak :PZ

symbol:	wymiar (mm)		
	M	d	L
LK 2,0 x10	2	3,0	6
LK 2,5 x12	2,5	3,0	8
LK 2,5 x10	2,5	3,0	10
LK 2,5 x12	2,5	3,0	12
LK 2,5 x16	2,5	3,0	16
LK 3,0 x 6	3	3,0	6
LK 3,0 x 8	3	3,0	8
LK 3,0 x10	3	3,0	10
LK 3,0 x12	3	3,0	12
LK 3,0 x16	3	3,0	16
LK 3,0 x20	3	3,0	6
LK 3,0 x25	3	3,0	8
LK 4,0 x10	4	4,0	10
LK 4,0 x12	4	4,0	12
LK 4,0 x16	4	4,0	16

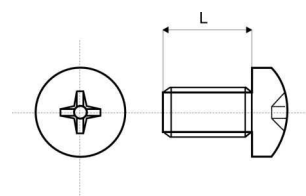

Śruby z łbem owalnym pod klucz trzpieniowy

Dane techniczne

materiał :stal 4,8
pokrycie :cynkowane
opakowanie :100 szt
pod wkrętak :...SW

symbol:	wymiary (mm)				
	M	SW	L	d1	k
LK 3,0 ISK x 6	3	2,0	6	5,5	1,6
LK 3,0 ISK x 8	3	2,0	8	5,5	1,6
LK 3,0 ISK x10	3	2,0	10	5,5	1,6
LK 3,0 ISK x12	3	2,0	12	5,5	1,6
LK 4,0 ISK x 6	4	2,5	6	7,5	2,1
LK 4,0 ISK x 8	4	2,5	8	7,5	2,1
LK 4,0 ISK x10	4	2,5	10	7,5	2,1
LK 4,0 ISK x12	4	2,5	12	7,5	2,1

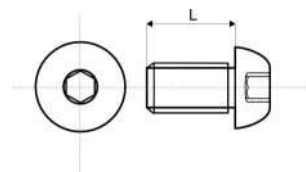

Śruby wpuszczane pod wkrętak krzyżakowy

Dane techniczne

material :stal 4,8
pokrycie :cynkowane
opakowanie :100 szt
pod wkrętak rodz. :PH

symbol: wymiary (mm)
M d L

GEW2,0x 6S 2 2,0 6
GEW2,0x 8S 2 2,0 8
GEW2,0x10S 2 2,0 10
GEW2,0x12S 2 2,0 12
GEW2,0x16S 2 2,0 16
GEW2,0x20S 2 2,0 20

GEW2,5x 6S 2,5 2,5 6
GEW2,5x 8S 2,5 2,5 8
GEW2,5x10S 2,5 2,5 10
GEW2,5x12S 2,5 2,5 12
GEW2,5x16S 2,5 2,5 16
GEW2,5x20S 2,5 2,5 20
GEW2,5x25S 2,5 2,5 25

GEW3,0x 6S 3 3,0 6
GEW3,0x 8S 3 3,0 8
GEW3,0x10S 3 3,0 10
GEW3,0x12S 3 3,0 12
GEW3,0x16S 3 3,0 16
GEW3,0x20S 3 3,0 20
GEW3,0x25S 3 3,0 25
GEW3,0x30S 3 3,0 30
GEW3,0x35S 3 3,0 35
GEW3,0x40S 3 3,0 40

GEW4,0x 6S 4 4,0 6
GEW4,0x 8S 4 4,0 8
GEW4,0x10S 4 4,0 10
GEW4,0x12S 4 4,0 12
GEW4,0x16S 4 4,0 16
GEW4,0x20S 4 4,0 20

GEW5,0x 8S 5 5,0 8
GEW5,0x10S 5 5,0 10
GEW5,0x12S 5 5,0 12
GEW5,0x16S 5 5,0 16
GEW5,0x20S 5 5,0 20

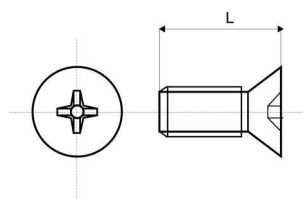

Podkładki

Dane techniczne

material :stal 4,8
pokrycie :cykowane
opakowanie :100 szt



symbol:	wymiary (mm)		
	D	d	S
USM 2,0	5,0	2,2	0,3
USM 2,5	6,5	2,7	0,5
USM 3,0	7,0	3,2	0,5
USM 4,0	9,0	4,3	0,8
USM 5,0	10,0	5,3	1,0

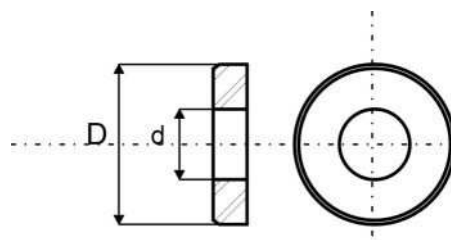

Podkładki koronkowe, zewnętrzne

Dane techniczne

material :stal HRC36-43
pokrycie :cykowane
opakowanie :100 szt

symbol:	wymiary (mm)		
	D	d2	S
ZS 3,0 A	6,0	3,2	0,4
ZS 4,0 A	8,0	4,3	0,5
ZS 5,0 A	10,0	5,3	0,6

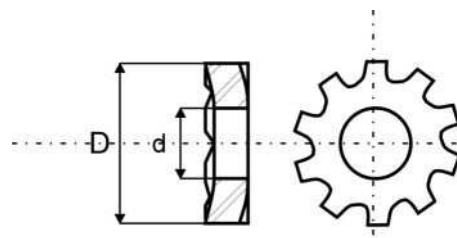

Nakrętki

Dane techniczne

material :stal 4,8
pokrycie :cynkowane
opakowanie :100 szt



symbol:	wymiary (mm)		
	M	S	H
SMM 2,0	2,0	4,0	1,6
SMM 2,5	2,5	5,0	2,0
SMM 3,0	3,0	5,5	2,4
SMM 4,0	4,0	7,0	3,2
SMM 5,0	5,0	8,0	4,0

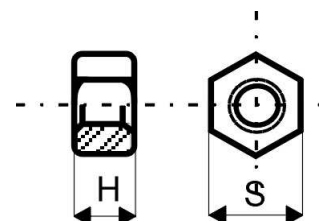

Blachowkręty z łbem owalnym pod wkrętak krzyżakowy

Dane techniczne

material :stal 4,8
pokrycie :cynkowane
opakowanie :100 szt
pod wkrętak :PH



symbol:	wymiar (mm)	
	d	L
BLSK 2,2 x 6,5	2,2	6,5
BLSK 2,9 x 6,5	2,9	6,5
BLSK 2,9 x 9,5	2,9	9,5
BLSK 3,9 x 9,5	3,9	9,5

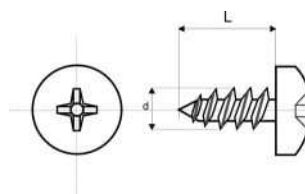

Śruby z łbem owalnym z podkładką pod wkrętak krzyżakowy

Dane techniczne

material :stal 4,8
pokrycie :niklowane
opakowanie :100 szt
pod wkrętak :PH

symbol:	wymiar (mm)		
	M	d1	L
GEW 3,0 x 06KF	3	7,5	6
GEW 3,0 x 08KF	3	7,5	8
GEW 4,0 x 08KF	4	9,2	8
GEW 4,0 x 10KF	4	9,2	8
GEW 5,0 x 08KF	5	12,0	8
GEW 5,0 x 10KF	5	12,0	10

